

# Press Tool / Milling Clamp

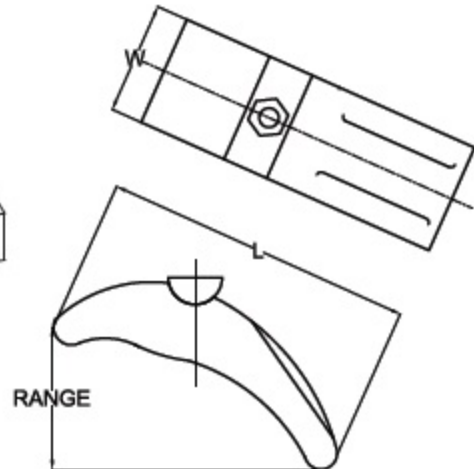
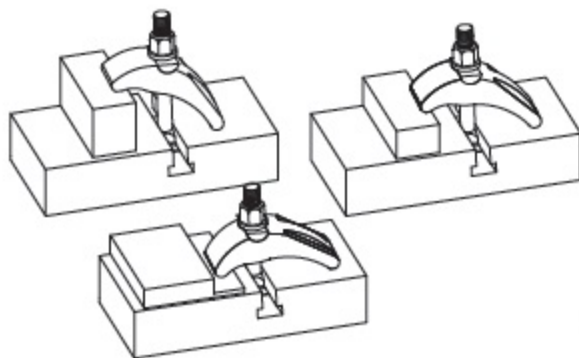

## Material

**Clamping Pad:** High tensile  
S.G. Iron Enamelled in Flame Red  
Colour

**T-Bolt, HN:** Medium Carbon Steel,  
Hardened and tempered to 24-32 HRC  
and Chemically Blackened

**Swivel Nut:** Medium Carbon Steel  
Chemically Blackened

## Applications :

- On Presses for holding tools, dies
- On Machine beds for holding flat components, castings.

## TYPE: T1-PTMC

TYPE	Suitable for T-Slot	Clamp		Range	T-Bolt type	Weight in kg (Full Set)
		Width	Length			
T1-PTMC-8	8	30	100	0-40	T2-TB-880	0.45
T1-PTMC-10	10	30	100	0-35	T2-TB-1080	0.45
T1-PTMC-12	12	50	140	0-55	T2-TB-12125	1.45
T1-PTMC-14	14	50	140	0-55	T2-TB-14125	1.45
T1-PTMC-16	16	50	140	0-70	T2-TB-16160	1.60
T1-PTMC-18	18	60	175	0-80	T2-TB-18200	2.60
T1-PTMC-20	20	60	175	0-90	T2-TB-20200	2.85
T1-PTMC-22	22	60	175	0-90	T2-TB-22200	2.90
T1-PTMC-24	24	65	235	0-140	T2-TB-24200	4.75
T1-PTMC-28	28	65	235	0-140	T2-TB-28200	4.85