

# Mould Clamp with Heavy Support Bolt

Mould Clamp offers counter height adjustment by heavy duty support bolt with hex, round base and lock nut.

**Material:** Medium Carbon Steel Hardened and tempered to 24-30 HRC and Chemically Blackened

**Applications :** Plastic Moulding machines

**Note:** T1-MCH is supplied with the Clamp, Support Bolt and Lock Nut. T-Bolt/Stud, Hex Hi-Nut and Washer are optional.

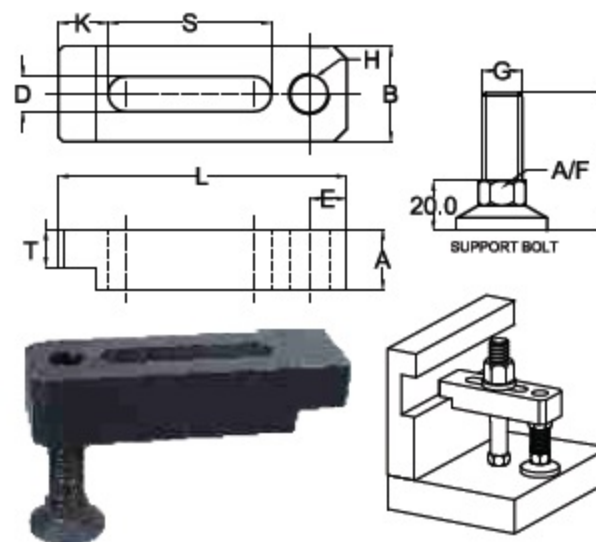

TYPE: T1-MCH												
TYPE	Bolt Size	A	B	D x L	S	T	K	H	E	Support Bolt		Weight in kg
										G x J	Hex A/F x Base	
T1-MCH-12115S	M12	24	38	14 x 115	65	15	20	M16	15	M16 x 55L	19 x 35	0.70
T1-MCH-12115L										M16 x 90L		0.75
T1-MCH-16130S	M16	31	48	18 x 130	70	20	25	M20	18	M20 x 60L	24 x 40	1.30
T1-MCH-16130L										M20 x 90L		1.35
T1-MCH-16160S	M16	31	48	18 x 160	90	20	30	M20	20	M20 x 60L	24 x 40	1.55
T1-MCH-16160L										M20 x 90L		1.60
T1-MCH-20140S	M20	38	60	22 x 140	70	25	35	M24	18	M24 x 60L	27 x 50	2.10
T1-MCH-20140L										M24 x 100L		2.20
T1-MCH-20160S	M20	38	60	22 x 160	90	30	35	M24	20	M24 x 60L	27 x 50	2.40
T1-MCH-20160L		45								M24 x 100L		2.90
T1-MCH-20200	M20	45	60	22 x 200	110	30	45	M24	22	M24 x 100L	27 x 50	3.50
T1-MCH-24200	M24	48	78	26 x 200	105	35	45	M27	25	M27 x 100L	30 x 55	5.00